

ARC2-H Roller Chain Conveyor Section
Instruction & Maintenance Manual
ARC2-H 滚子链输送段安装使用维护手册

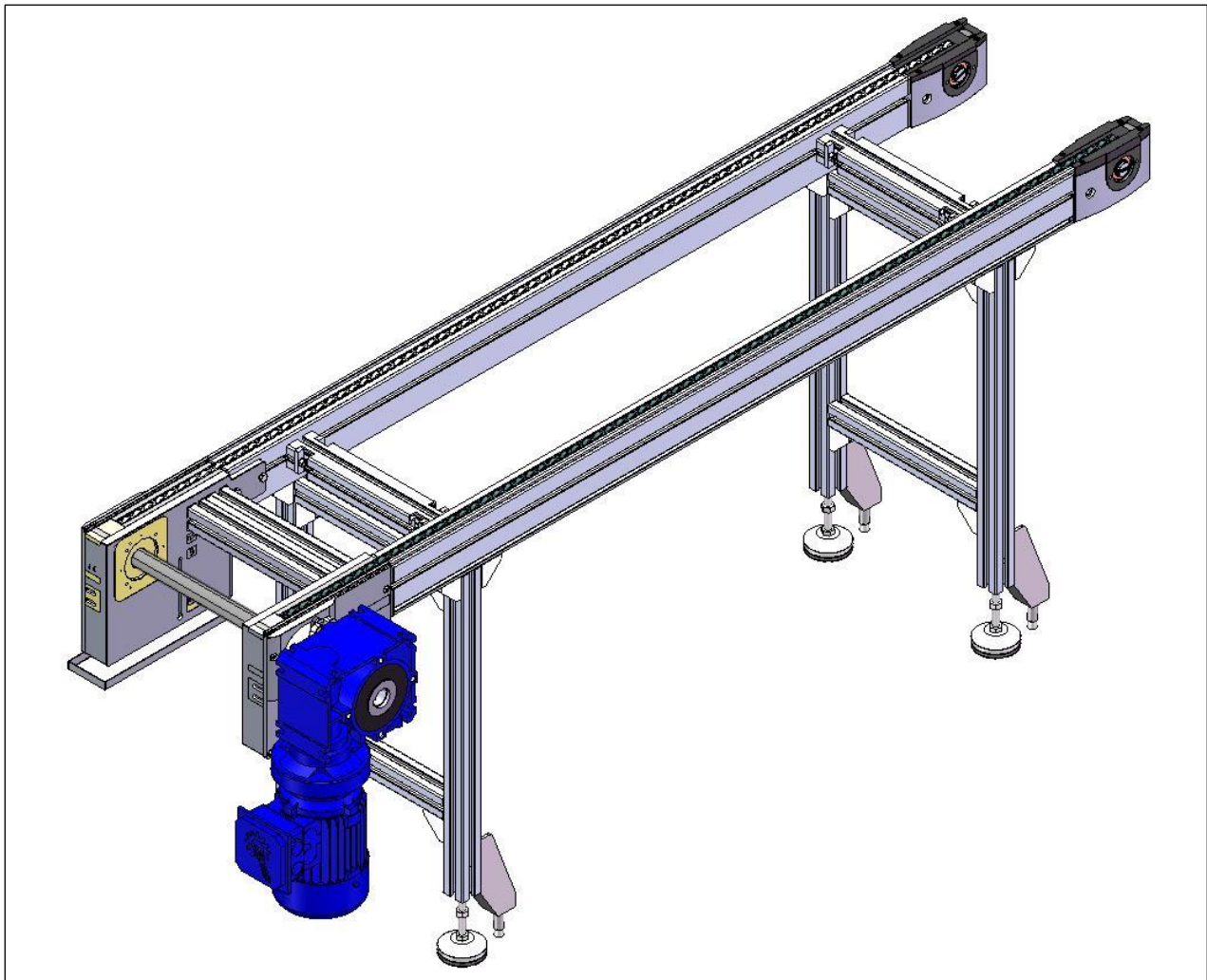

Suzhou LinkedGo Transfer System Co.,Ltd.

苏州领科工业技术有限公司

Structure Diagram 结构示意图

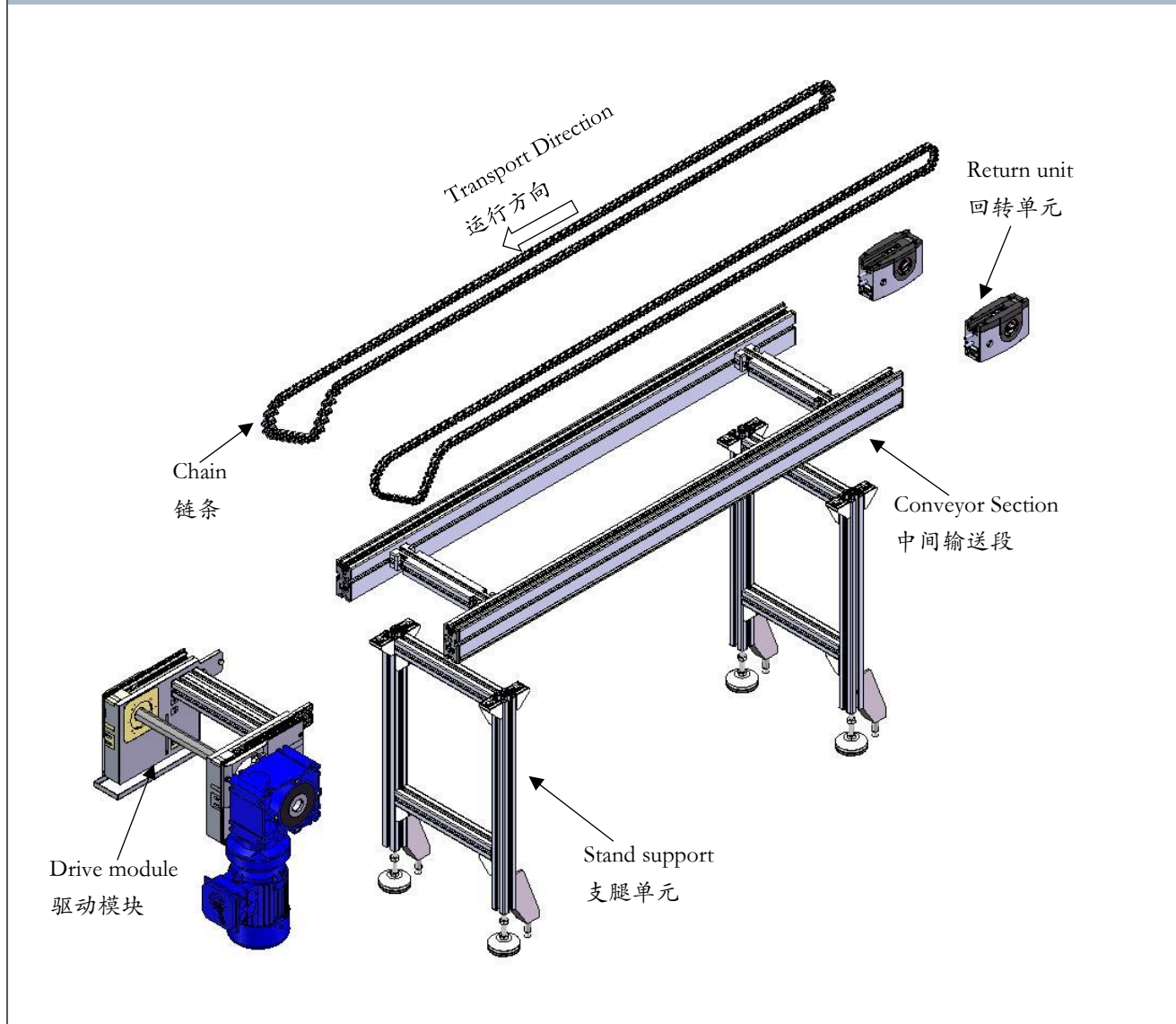

产
品
特
征

安
装
步
骤

维
护
保
养

- 1、 The length L of the straight section is 650-6000mm, and the width can be customized according to customer requirements.
- 1、 直线段长度 L 为 650-600mm，宽度可根据客户要求定制。
- 2、 The conveying medium is a stacked roller chain, with polyamide or steel material stacked rollers.
- 2、 输送介质为堆积滚子链，聚酰胺或钢材质堆积滚轮。
- 3、 The maximum conveying section load during stacking operation is 1200kg.
- 3、 堆积操作中的最大输送段负载为 1200kg。
- 4、 It can operate in reverse when $L \leq 2000\text{mm}$.
- 4、 在 $L \leq 2000\text{mm}$ 时可反向运行。
- 5、 The motor can be installed on the right, left, and middle of the line (* when the conveying section width $B \geq 240\text{mm}$).
- 5、 电机可安装在线体右侧、左侧和中间* (*当输送段宽度 $B \geq 240\text{mm}$)。

Model Description 型号说明

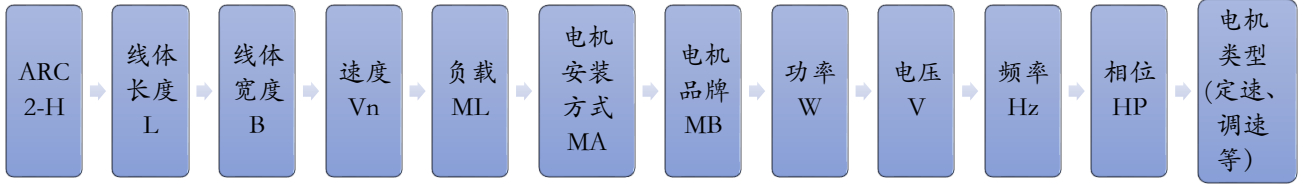

例：ARC2-H - L2810 - B420 - Vn12 - ML30 - MAL011A - NORD - 120W - 380V - 50Hz - 3HP - C0

The model ARC2-H-L2810-B420-Vn12-ML30-MAR011A-NORD-120W-380V-50Hz-3HP-C0 represents a fixed speed motor with a line length of 2810mm, a line width of 420mm, a running speed of 12m/min, a running load of 30kg, a motor installation position of L011A, a motor brand of NORD, a power of 120W, a voltage of 380V, a frequency of 50Hz, and a phase of 3.

型号 ARC2-H-L2810--B420-Vn12-ML30-MAR011A-NORD-120W-380V-50Hz-3HP-C0，表示线体长度 2810mm，线体宽度 420mm，运行速度 12m/min，运行负载 30kg，电机安装位置为 L011A，电机品牌为 NORD，功率为 120W，电压为 380V，频率为 50Hz，相位为 3 的定速电机。

参数说明 Parameter Description

品名 Product Name	长度(mm) Length	宽度(mm) Width	速度 (m/min) Speed	电机安装方式 Motor installation method
ARC2-H	650~6000	400~1200	8~20	电机安装：MA=①_②_③_④_⑤_ Motor installation: MA=①_②_③_④_⑤_ ①电机安装位置：M 中置；R=右；L=左； Motor installation position: M center; R=right; L=Left; ②当①=R/L 时，②=0；当①=M 时，②=R/L； ② When ①=R/L, ②=0; When ①=M, ②=R/L; ③电机安装位置：1、2、3、4； Motor installation position: 1, 2, 3, 4; ④接线盒位置：1、2、3、4； Location of junction box: 1, 2, 3, 4; ⑤出线口方向：A、B、C、D； Outlet direction: A, B, C, D;

产品特征

安装步骤

维护保养

电机安装位置 Motor installation position

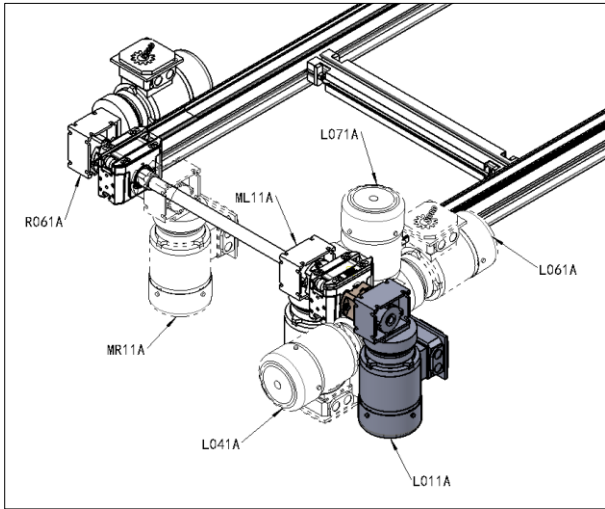

注：图为电机 L011A 的安装方式。

产品特征

安装步骤

维护保养

安装步骤 Installation steps

A Install the body profile as shown in the following figure.

A 按下图所示，安装机身型材。

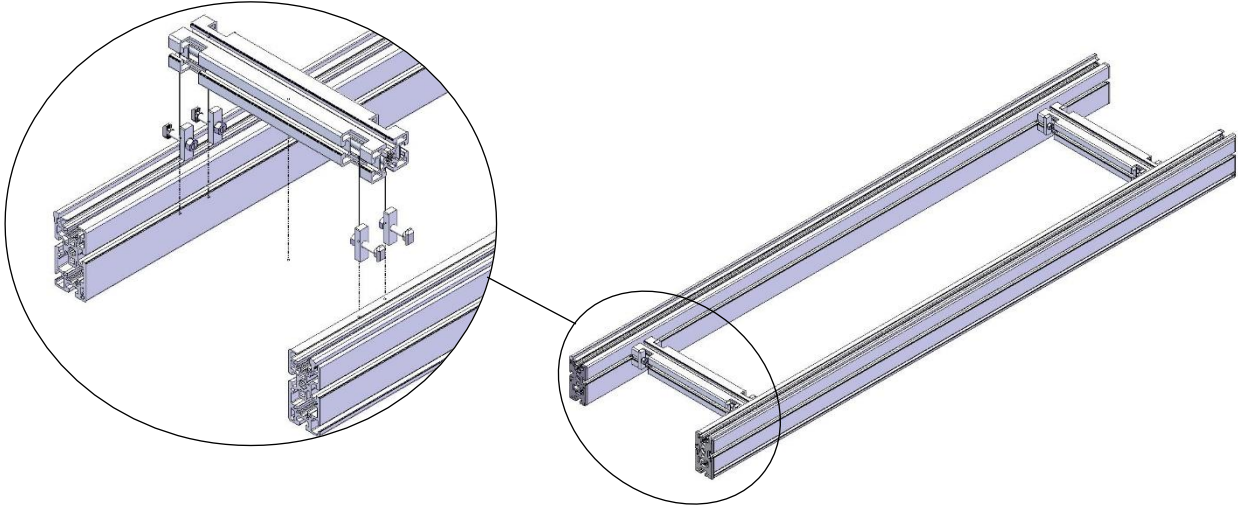

B Assemble the stand support onto the Conveyor Section as indicated below.

B 按下图所示，将支腿单元安装到中间输送段上。

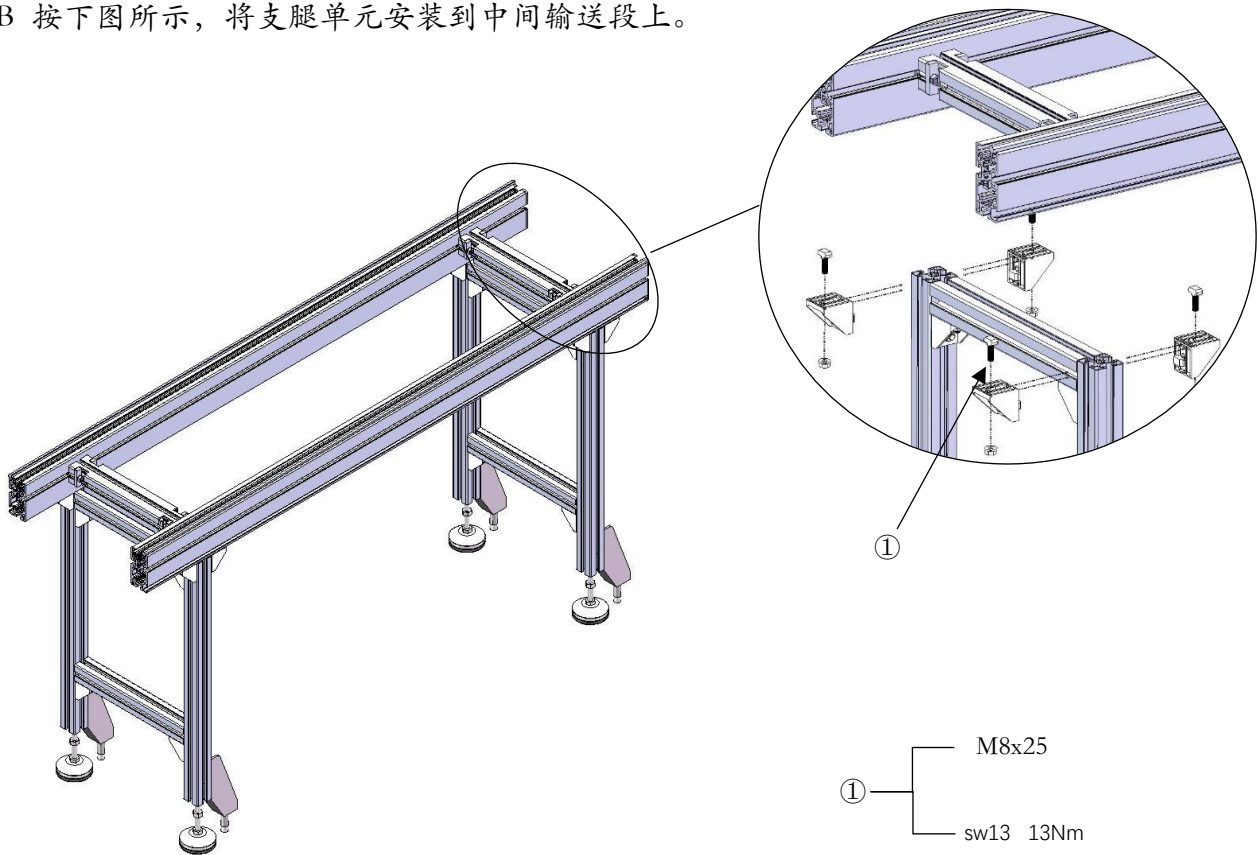

产品特征

安装步骤

维护保养

C Install the drive unit and rotary unit at both ends of the wire body as shown in the following figure.

C 按下图所示，将驱动单元、回转单元安装于线体两端。

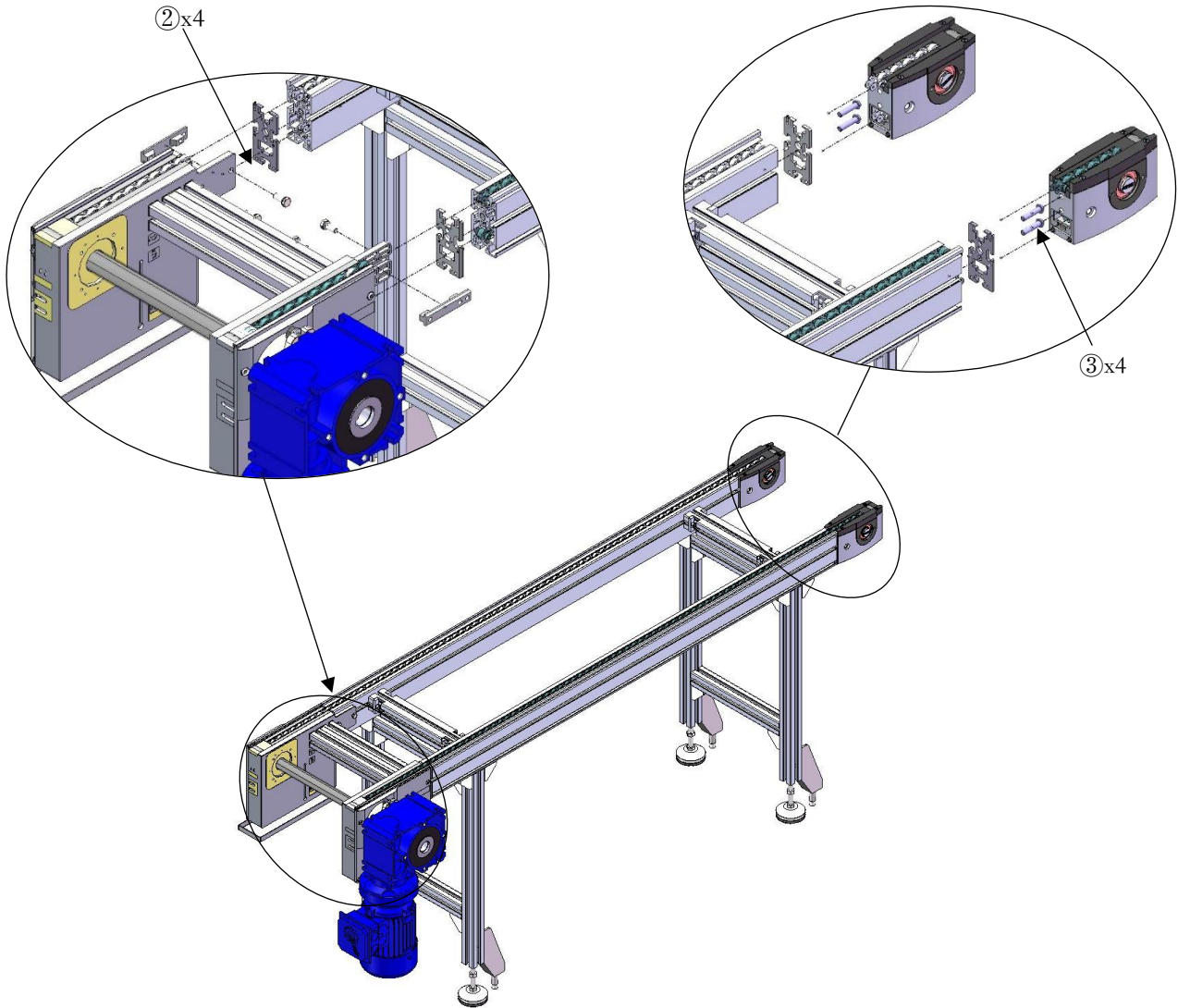

② — M8x20
⑥ 13Nm

③ — M8x35
⑥ 13Nm

产品特征

维护保养

安装步骤

D The chain disc is on the chain line, and the chain is threaded in the direction of the arrow to avoid twisting and damage during the threading process.

D 链条盘在链条线上，将链条按照箭头方向的走向穿入，在穿入过程中避免链条扭拧损坏。

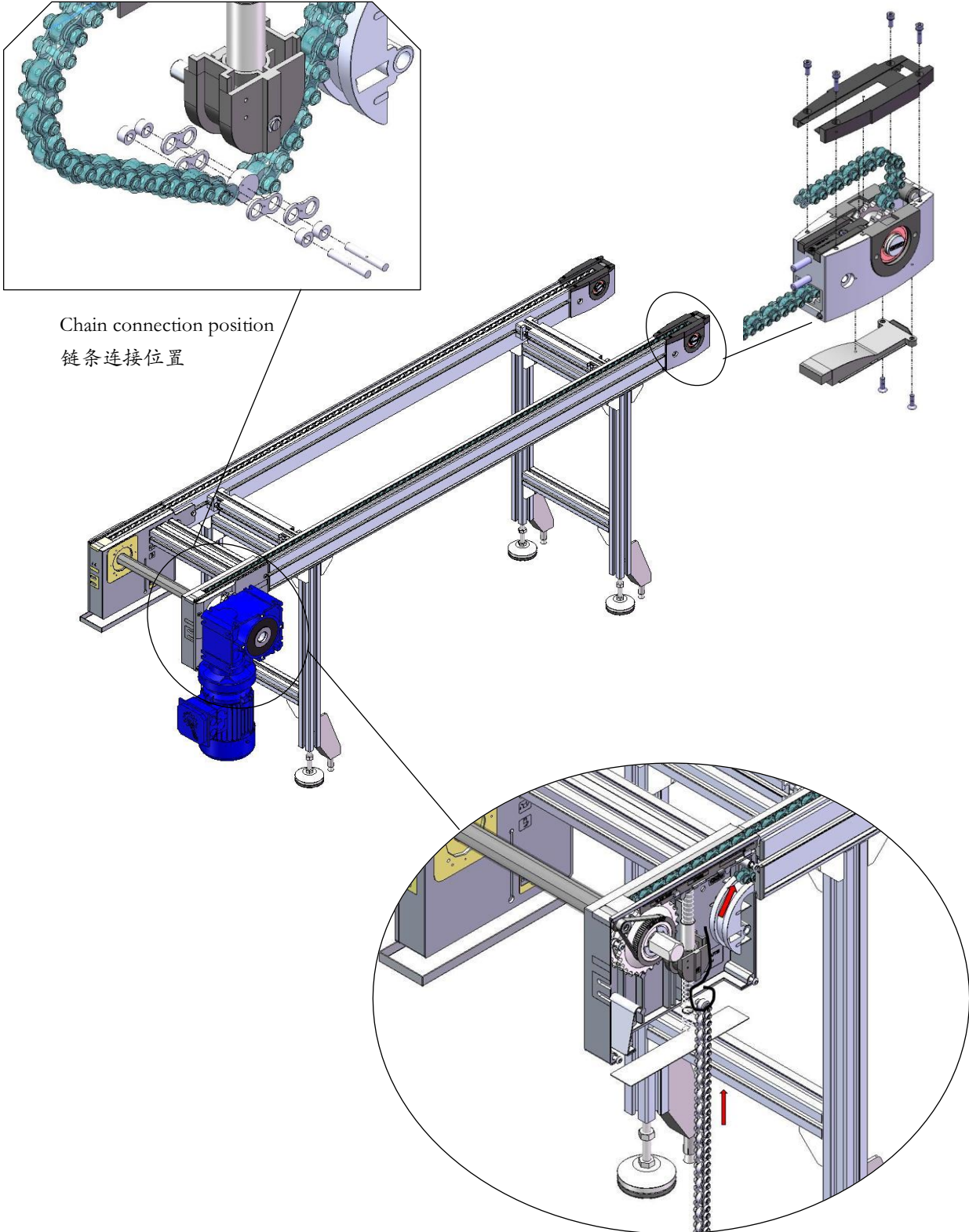

产品特征

安装步骤

维护保养

F Installing the motor.

F 安装电机

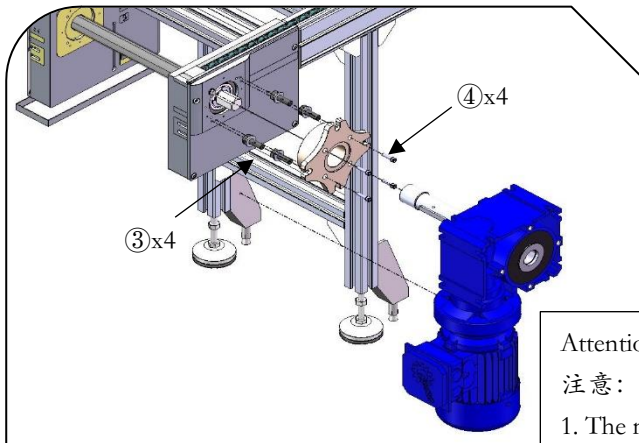

Attention:

注意:

1. The motor should be installed firmly and not tilted.
- 1、电机安装稳固不能倾斜。
2. The direction of the motor and junction box must meet the technical requirements.
- 2、电机与接线盒方向必须符合技术要求。

G Regular Troubleshooting.

G 常见故障及处理方法。

1. Abnormal noise from the drive module or rotary unit: Check if the bearings need lubrication, and replace the driven wheel set if necessary.

1、驱动模块或回转单元异响：检查轴承是否需要润滑，必要时更换从动轮组。

2. Motor overheating: Check if the equipment is operating under overload and if the motor wiring is loose.

2、电机过热：检查设备是否超载运作，电机接线是否松动。

3. Chain abnormal noise: This situation often occurs when a foreign object falls into the chain gap, and the machine needs to be stopped to remove the foreign object.

3、链条异响：这种情况发生多由有异物掉入链条间隙，此时需停机将异物取出。

Maintenance 维护和保养

The UTS series tray conveying system requires regular maintenance and upkeep to extend the service life of the line. The conveying equipment should be kept clean to avoid direct sunlight or rain or snow, and to prevent contact with substances such as acids, alkalis, oils, organic solvents, etc.

UTS 系列托盘输送系统需按周期进行规定的保养维护工作，以延长线体使用寿命。输送设备应保持清洁避免阳光直射或雨雪浸淋，防止与酸、碱、油类、有机溶剂等物质接触。维护前需关闭对应的能源供给。

Daily Maintenance

日维护

Regularly clean the conveyor line. Before starting the machine every day, it is necessary to clean the floating dust, falling small parts, and other obstacles on the belt and wire body to prevent dust and dirt from affecting the operation of the wire body. When cleaning the machine head, it is necessary to remove the upper cover of the machine head, and use an air gun to remove the accumulated dust inside. During trial operation, check whether there are any abnormalities in various parts of the conveyor line, such as loose bearings or abnormal noise. Once any abnormalities are found, repair and replace them immediately.

定期清洁输送线。每日开机前需清理皮带及线体上的浮尘、掉落的小零件及其他障碍物，防止积尘和污垢影响线体运行。在清洁机头时，需拆掉机头上盖，用气枪清除里面积压的灰尘。试运行前，检查输送线的各部位是否有异常，如轴承有无松动或异常噪音，一旦发现异常应立即维修和更换。

Weekly Maintenance

周维护

Regularly inspect the accessories on the conveyor line body. For parts that are prone to damage such as bearings, and idlers, regular inspection, maintenance, and lubrication are required. If damage or looseness is found, it must be replaced immediately. Check if the fasteners on the wire body are loose and tighten them in a timely manner.

定期检查输送线体上的附件。对于轴承、惰轮等容易损坏的零件，需定期检查、保养和润滑。发现损坏和松动须立即更换。检查线体上的紧固件是否有松动情况，及时紧固。

Monthly Maintenance

月维护

Regularly clean motor bearings, check for wear, and replace lubricating oil in a timely manner. (It is necessary to replenish the oil at any time based on the on-site operating conditions and the degree of oil volatilization. Under normal operation, the lubricating oil can be replaced every six months.)

对于电机轴承等定期清洗，检查磨损情况，及时更换润滑油。（需根据现场运行状况及油脂挥发程度进行随时补油，正常运行下，可六个月更换一次润滑油。）

Quarterly Maintenance

季度维护

Check the wear of bearings, idlers, pulleys, and synchronous wheels, replace them in a timely manner, and pay special attention to observing whether the chain is loose. If the tensioning slider moves down, it is necessary to use a roller chain dismantling tool to remove the chain links to shorten the chain length.

检查轴承、惰轮、滑轮、同步轮的磨损情况，及时更换，特别注意观察链条是否发生松弛情况，若张紧滑块下移，则需要用滚子链拆链条工具去除链节来缩短链条长度。

Chain Maintenance

链条维护

Before starting the machine for the first time, the steel wheel chain must be lubricated, and the equipment must be re lubricated after being shut down for 6 months or more. Lubrication method: 1. Remove oil stains and impurities from the chain. 2. Apply approximately 1-2ml/m of oil per meter of chain to the chain. 3. When lubricating used chains, it is necessary to check for wear and elongation of the chains

首次开机前，钢制轮链条必须润滑，设备停机 6 个月及以上需重新润滑。润滑方式：1、清除链条上油污、杂质。2、用大约 1—2ml/每米链条的油量给链条上油。3、在给使用过的链条上润滑时，需检查链条是否磨损、伸长。

When the equipment is in normal use, the chain needs to be lubricated every 2000 hours, using approximately 1ml/meter of lubricating oil for each lubrication.

设备正常使用时，链条每 2000 小时需进行润滑，每次润滑用大约 1ml/每米的润滑油。

When the environmental humidity is high, it is necessary to shorten the lubrication cycle according to the actual situation. 在环境湿度较大时，需根据实际情况缩短润滑周期。

Disclaimer

免责声明

The customer shall inspect the equipment regularly. If the customer fails to maintain the conveyor as the state above, leading to any malfunction or damage to the conveyor, our company will not be responsible for it, all related costs (including material costs, installation and commissioning fees, and hotel expense) shall be borne by the customer.

客户应定期对设备进行检查。若客户未按要求对输送机进行维护，进而导致输送机发生任何故障或损坏，我司将不承担相关责任，由此产生的相关费用（材料费，安装调试费，差旅费）均由客户承担。

Suzhou LinkedGo Transfer System Co.,Ltd.
苏州领科工业技术有限公司

[Tel: +86-512-6636 1885](tel:+86-512-66361885)

Add: Room 706, Building D, Dongchuang Science and Technology Park, No.
216 Jinfeng Road, Wuzhong District, Suzhou, P.R. China

Zip code:215101

E-mail: Sales@LinkedGo.com.cn

Website: [www. LinkedGo.com.cn](http://www.LinkedList.com.cn)

Subject to technical modifications

电话：+86-512-6636 1885

地址：苏州市吴中区木渎镇金枫路 216 号东创科技园 D 幢 706 室

邮编：215101

邮箱：Sales@LinkedGo.com.cn

网址：www.LinkedList.com.cn

我司保留技术更改的权利